



■ Features :

- Universal AC input / Full range
- 3 pole AC inlet IEC320-C14
- Built-in active PFC function, PF>0.95
- Class I power (with earth pin)
- Protections: Short circuit / Overload / Over voltage / Over temperature
- Fully enclosed plastic case
- LED indicator for power on
- No load power consumption < 1W @240VAC
- 2 years warranty



SPECIFICATION

MODEL		ATX-100				
OUTPUT	OUTPUT NUMBER	CH1	CH2	CH3	CH4	CH5
	DC VOLTAGE	3.3V	5V	12V	-12V	5VSB
	RATED CURRENT	5A	6A	3.75A	0.3A	1A
	CURRENT RANGE	0 ~ 6A	0 ~ 8A	1 ~ 7A	0 ~ 0.5A	0 ~ 2A (Note.7)
	RATED POWER <small>Note.8,9</small>	50W		-----		
		100W(continue), 125W(7min.), 150W(3min.)				
	RIPPLE & NOISE (max.) <small>Note.2</small>	100mVp-p	100mVp-p	120mVp-p	120mVp-p	100mVp-p
	VOLTAGE TOLERANCE <small>Note.3</small>	±5.0%	±5.0%	±5.0%	±10%	±5.0%
	LINE REGULATION	±1.0%	±1.0%	±1.0%	±1.0%	±1.0%
	LOAD REGULATION	±5.0%	±5.0%	±5.0%	±10%	±5.0%
SETUP, RISE TIME	3000ms, 80ms at full load					
HOLD UP TIME(Typ.)	40ms at full load					
INPUT	VOLTAGE RANGE <small>Note.10</small>	90 ~ 264VAC		127 ~ 370VDC		
	FREQUENCY RANGE	47 ~ 63Hz				
	POWER FACTOR (Typ.)	PF>0.95 at full load				
	EFFICIENCY(Typ.)	80%				
	AC CURRENT (Typ.)	1.4A/115AVC		0.7A/230VAC		
	INRUSH CURRENT (Typ.)	COLD START < 60A at 230VAC				
	LEAKAGE CURRENT (max.)	<2mA / 240VAC				
PROTECTION	OVERLOAD	6.2A min.	8.2A min.	7.2A min.	-----	-----
		Protection type : Shut down o/p voltage(except for 5VSB), re-power on to recover				
	OVER VOLTAGE	3.7 ~ 4.1V	5.7 ~ 6.5V	13.2 ~ 14.4V	-----	-----
	Protection type : Shut down o/p voltage(except for 5VSB), re-power on to recover					
OVER TEMPERATURE	100°C ±5°C (TSW1:detect on heatsink of power transistor)					
	Protection type : Shut down o/p voltage(except for 5VSB), re-power on to recover					
SIGNAL FUNCTION	POWER OK	TTL compatible signal with 100 ~ 500ms delay after set up				
	PS-ON	Power ON:PS-ON="Low" or "<0.8V"; Power OFF:PS-ON="Hi" or ">2V"				
ENVIRONMENT	WORKING TEMP.	0 ~ +50°C (Refer to "Derating Curve")				
	WORKING HUMIDITY	20 ~ 90% RH non-condensing				
	STORAGE TEMP., HUMIDITY	-20 ~ +85°C, 10 ~ 95% RH non-condensing				
	TEMP. COEFFICIENT	±0.05%/°C (0 ~ 60°C)				
	VIBRATION	10 ~ 500Hz, 2G 10min./1cycle, period for 60min. each along X, Y, Z axes				
SAFETY & EMC (Note 6)	SAFETY STANDARDS	Design refer to UL60950-1, IEC60950-1 CB approved by TUV				
	WITHSTAND VOLTAGE	I/P-O/P:3KVAC				
	ISOLATION RESISTANCE	I/P-O/P:>100M Ohms / 500VDC / 25°C / 70% RH				
	EMC EMISSION	Compliance to EN55022 (CISPR22) Class B, EN61204-3, EN61000-3-2,-3				
	EMC IMMUNITY	Compliance to EN61000-4-2,3,4,5,6,8,11, EN55024, light industry level, criteria A				
OTHERS	MTBF	152K hrs min. MIL-HDBK-217F (25°C)				
	DIMENSION	210*85*46mm(L*W*H)				
	PACKING	1.12Kg; 12pcs/14.5Kg/0.95CUFT				
NOTE	<ol style="list-style-type: none"> 1. All parameters NOT specially mentioned are measured at 230VAC input, rated load and 25°C of ambient temperature. 2. Ripple & noise are measured at 20MHz of bandwidth by using a 12" twisted pair-wire terminated with a 0.1uf & 47uf parallel capacitor. 3. Tolerance : includes set up tolerance, line regulation and load regulation. 4. Line regulation is measured from low line to high line at rated load. 5. Each output power up to maximum current, but total load cannot exceed maximum output power(100W). 6. The power supply is considered a component which will be installed into a final equipment. The final equipment must be re-confirmed that it still meets EMC directives. 7. 5VSB peak load 2A< 10sec. 8. Total power of 5V, 3.3V should less than 50W. 9. 125W peak load duty 7min./hr, 150W peak load duty 3min./hr. 10. Derating may be needed under low input voltage. Please check the derating curve for more details. 11. 2 years warranty is based on 12hrs/day of operating time for the unit. 12. The ambient temperature derating of 3.5°C/1000m with fanless models and of 5°C/1000m with fan models for operating altitude higher than 2000m(6500ft). 					

Mechanical Specification

Case No.961A

Unit:mm

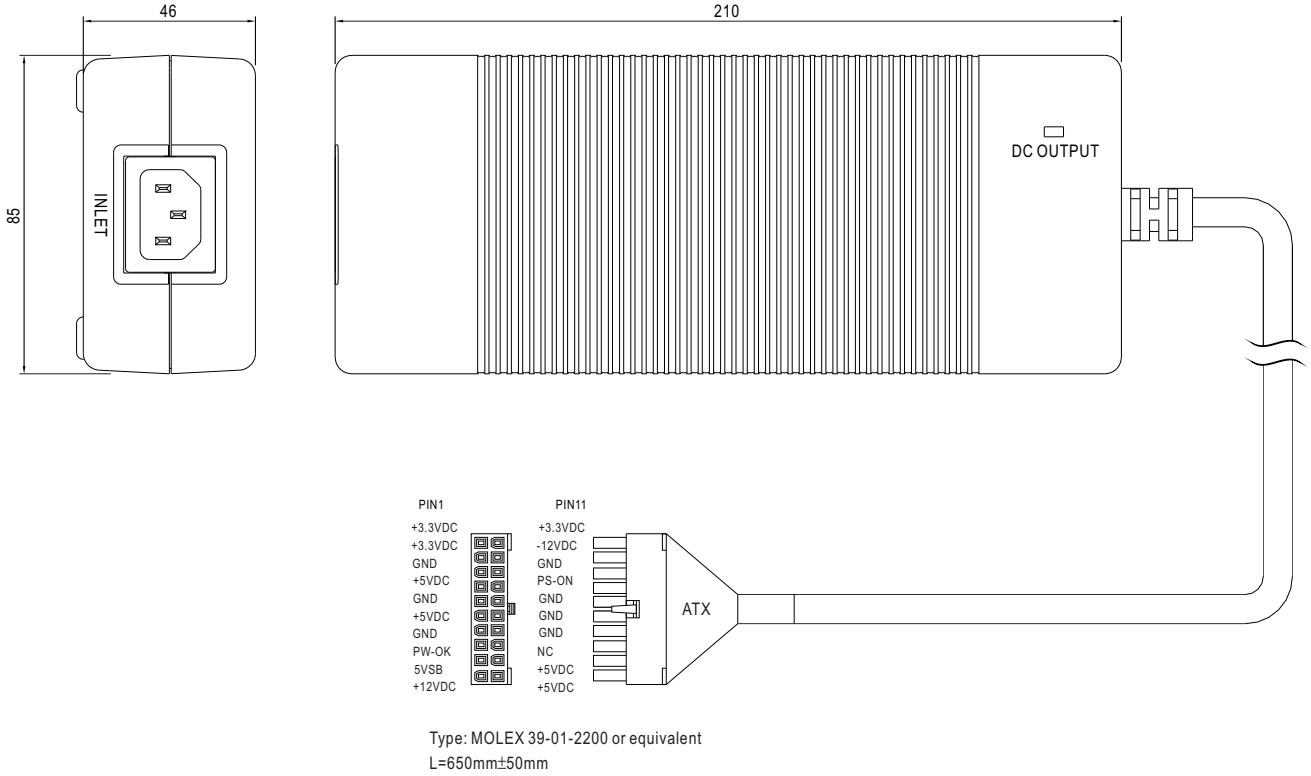

Block Diagram

fosc : 88KHz

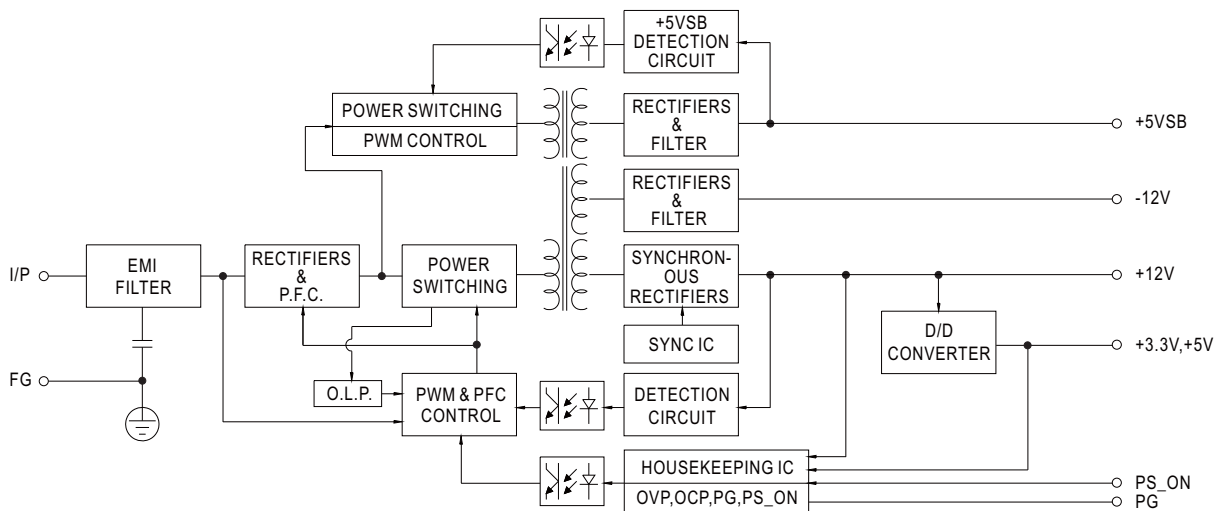

Sequence

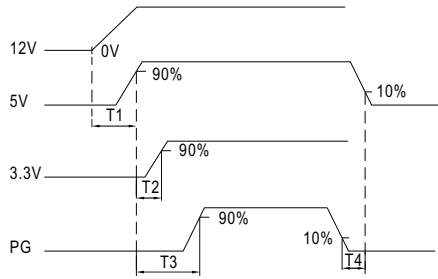

T1 : 0~20ms ($\pm 20\%$)
 T2 : 0~15ms ($\pm 20\%$)
 T3 : 100~500ms
 T4 : 0~30ms

Derating Curve

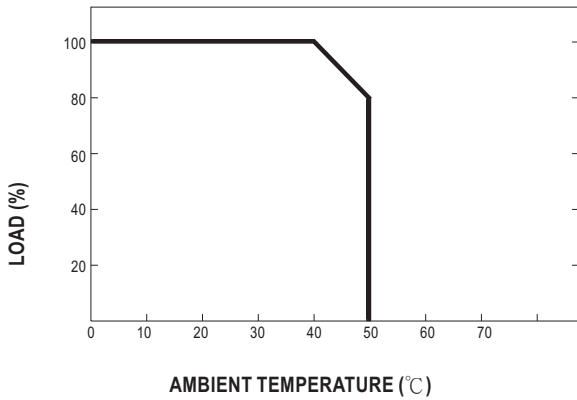

Output Load VS Input Voltage

