

■ Features :

- Isolated output & GND for CH1,CH2
- AC input range selected by switch
- Protections:Short circuit / Overload
- Cooling by free air convection
- Output is isolated from the others
- 100% full load burn-in test
- Fixed switching frequency at 25KHz
- Low cost
- High reliability
- 1 year warranty

SPECIFICATION

MODEL		ID-30B	
OUTPUT	OUTPUT NUMBER	CH1	CH2
	DC VOLTAGE	5V	24V
	RATED CURRENT	2.2A	1A
	CURRENT RANGE	0.1 ~ 2.2A	0.1 ~ 1A
	RATED POWER	35W	
	RIPPLE & NOISE (max.) Note.2	100mVp-p	150mVp-p
	VOLTAGE ADJ. RANGE	CH1 : 4.6 ~ 5.5V	
	VOLTAGE TOLERANCE Note.3	±2.0%	±7.0%
	LINE REGULATION	±0.5%	±0.5%
	LOAD REGULATION	±1.5%	±6.5%
	SETUP, RISE TIME	250ms, 100ms at full load	
HOLD TIME (Typ.)	40ms at full load		
INPUT	VOLTAGE RANGE	90 ~ 132VAC / 180 ~ 264VAC selected by switch on PCB 248 ~ 370VDC	
	FREQUENCY RANGE	47 ~ 63Hz	
	EFFICIENCY(Typ.)	72%	
	AC CURRENT (Typ.)	0.8A/110VAC	0.4A/220VAC
	INRUSH CURRENT (Typ.)	15A/110VAC	30A/220VAC
PROTECTION	OVER LOAD	105 ~ 150% rated output power	
		Protection type : Hiccup mode, recovers automatically after fault condition is removed	
ENVIRONMENT	WORKING TEMP.	-10 ~ +60°C (Refer to "Derating Curve")	
	WORKING HUMIDITY	20 ~ 90% RH RH non-condensing	
	STORAGE TEMP., HUMIDITY	-20 ~ +85°C, 10 ~ 95%	
	TEMP. COEFFICIENT	±0.05%/°C	
SAFETY & EMC	VIBRATION	10 ~ 500Hz, 2G 10min./1cycle, period for 60min. each along X, Y, Z axes	
	SAFETY STANDARDS	Design refer to UL1012	
	WITHSTAND VOLTAGE	I/P-O/P:1.5KVAC I/P-FG:1.5KVAC O/P-FG:0.5KVAC	
	ISOLATION RESISTANCE	I/P-O/P, I/P-FG, O/P-FG:100M Ohms / 500VDC / 25°C / 70% RH	
OTHERS	EMC EMISSION	Design refer to FCC Part15 J Conduction Class A	
	MTBF	597.7K hrs min. MIL-HDBK-217F (25°C)	
	DIMENSION	129*98*38mm (L*W*H)	
NOTE	PACKING	0.41Kg; 30pcs/13.4Kg/0.86CUFT	
	<p>1. All parameters NOT specially mentioned are measured at 230VAC input, rated load and 25°C of ambient temperature. 2. Ripple & noise are measured at 20MHz of bandwidth by using a 12" twisted pair-wire terminated with a 0.1uf & 47uf parallel capacitor. 3. Tolerance : includes set up tolerance, line regulation and load regulation.</p>		

Mechanical Specification

Case No. 903 Unit:mm

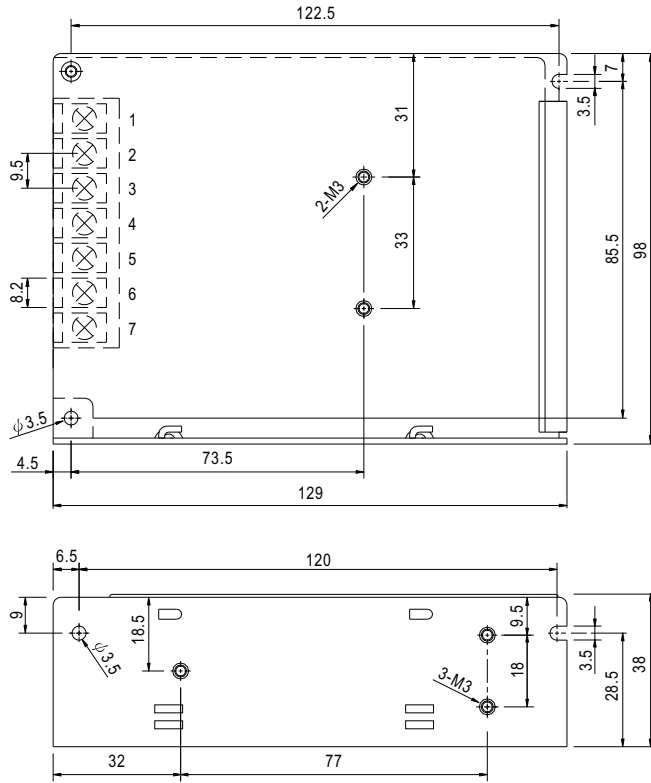

Terminal Pin No. Assignment

Pin No.	Assignment	Pin No.	Assignment
1	AC/L	5	DC OUTPUT +V
2	AC/N	6	DC OUTPUT G1
3	FG =	7	DC OUTPUT +5V
4	DC OUTPUT G2		

Block Diagram

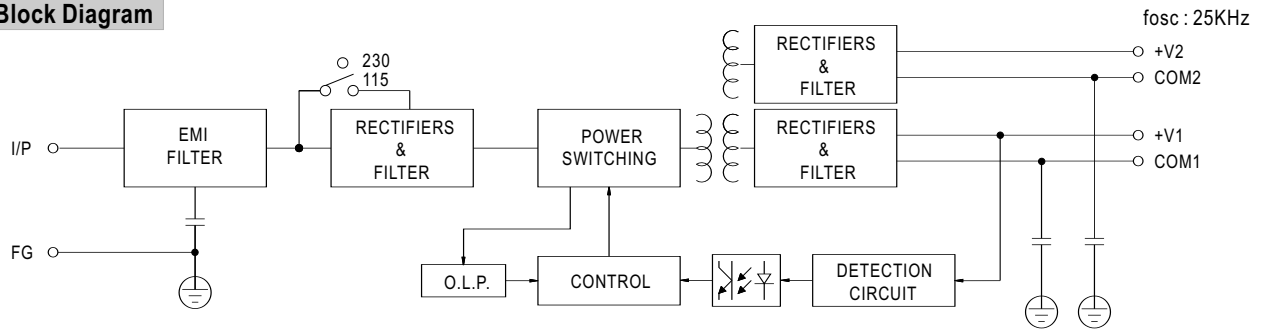

Derating Curve

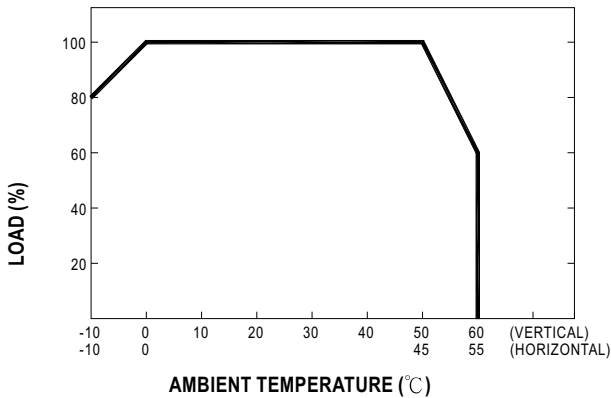

Static Characteristics (B)

