

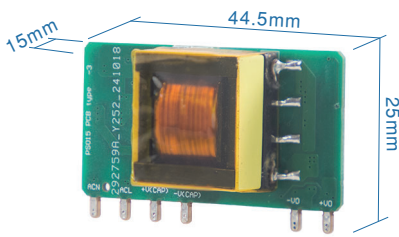

Наличие и актуальные цены на

IOB-15-24C

<https://www.mean-well.ru/store/IOB-15-24C/>



IOB-15-xxA

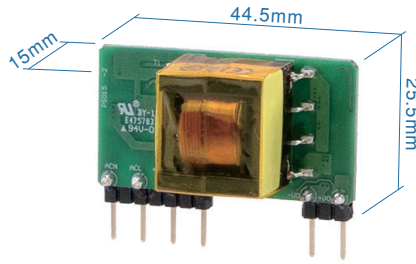

IOB-15-xxB

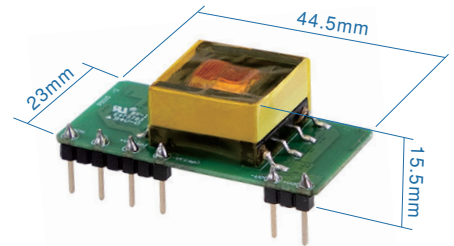

IOB-15-xxC



■ Features

- Assemble on the main PCB of the system
- 1.75"x0.86"compact size
- 85~305Vac input (277Vac available)
- No load power consumption <0.25W
- -40~85°C wide operating temperature
- Protections: Short circuit / Overload / Over voltage
- Cooling by free air convection
- Safety Class II
- 3 years warranty

■ Applications

- Industrial electrical equipment
- Mechanical equipment
- Factory automation equipment
- Hand-held electronic device
- Smart home
- Industrial control

■ GTIN CODE

MW Search: <https://www.meanwell.com/serviceGTIN.aspx>

■ Description

The IOB-15 series is a compact and reliable AC-DC open frame power module featuring high efficiency and low power consumption. It is particularly well-suited for space-constrained applications with stringent energy efficiency requirements. The product features a compact design and supports universal input voltage range of 85~305Vac. With ultra-low standby power consumption <0.25W, it is energy efficiency and eco-friendly. It also offers an ultra-wide operating temperature range of -40°C~+85°C as well as complete protection functions to ensure safe and reliable operation. These features make the product suitable for applications with strict space constraints, such as industrial automation, power metering, and smart devices.

■ Model Encoding

IOB - 15 - 05 A

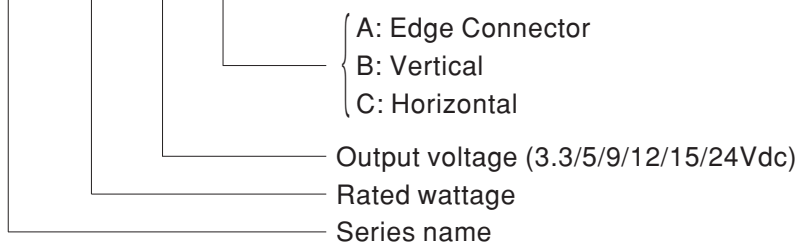

SPECIFICATION	IOB-15-03	IOB-15-05	IOB-15-09	IOB-15-12	IOB-15-15	IOB-15-24
	□ = A, B, C					
OUTPUT						
DC VOLTAGE	3.3V	5V	9V	12V	15V	24V
RATED CURRENT	3A	2.8A	1.67A	1.25A	1A	0.625A
CURRENT RANGE	0 ~ 3A	0 ~ 2.8A	0 ~ 1.67A	0 ~ 1.25A	0 ~ 1A	0 ~ 0.625A
RATED POWER	9.9W	14W	15W	15W	15W	15W
RIPPLE & NOISE (max.) Note.2	150mV					
INITIAL SET POINT ACCURACY	± 3% for 3.3Vdc output, ± 2% for other output					
LINE REGULATION	± 0.5%					
LOAD REGULATION	± 2% for 3.3Vdc output, ± 1.5% for 5Vdc output, ± 1% for other output					
CAPACITOR LOAD (Max.)	20000µF	15000µF	5000µF	4000µF	2000µF	1000µF
INPUT						
VOLTAGE RANGE	85 ~ 305Vac 100 ~ 430Vdc					
FREQUENCY RANGE	47 ~ 63Hz					
EFFICIENCY (Typ.)	75%	77%	82%	82%	84%	85%
AC CURRENT (Typ.)	0.4A/115Vac 0.25A/230Vac					
INRUSH CURRENT (Typ.)	18A/115Vac 35A/230Vac					
NO LOAD POWER CONSUMPTION	<0.25W					
PROTECTION						
SHORT CIRCUIT	Protection type : Continuous, automatic recovery, Hiccup mode					
OVERLOAD	>110% rated output power Protection type : Hiccup mode, recovers automatically after fault condition is removed					
OVER VOLTAGE (Max.)	9Vdc	9Vdc	12Vdc	16Vdc	20Vdc	30Vdc
	Protection type : Output voltage clamp					
ENVIRONMENT						
COOLING	Free-air convection					
WORKING TEMP. Note.4	-40 ~ +85°C (Refer to "Derating Curve")					
WORKING HUMIDITY	20% ~ 90% RH non-condensing					
STORAGE TEMP., HUMIDITY	-40 ~ +105°C, 10 ~ 95% RH non-condensing					
TEMP. COEFFICIENT	± 0.15% / °C max. (0 ~ 85°C)					
VIBRATION	10 ~ 500Hz, 2G 10min./1cycle, period for 60min. each along X, Y, Z axes					
SAFETY & EMC (Note.5)						
SAFETY STANDARDS	LVD IEC62368-1 approved					
WITHSTAND VOLTAGE	I/P-O/P:3KVac leakage current <5mA					
ISOLATION RESISTANCE	I/P-O/P:1000M Ohms / 500Vdc / 25°C / 70% RH					
EMC EMISSION	Parameter	Standard			Test Level / Note	
	Conducted	BS EN/EN55032(CISPR32)			Class A without external components	
	Radiated	BS EN/EN55032(CISPR32)			Class B with external components	
EMC IMMUNITY	Parameter	Standard			Test Level / Note	
	ESD	BS EN/EN61000-4-2			Level 3, ±6KV contact criteria B	
	Radiated Susceptibility	BS EN/EN61000-4-3			Level 3, 10mV contact criteria A	
	EFT/Bursts	BS EN/EN61000-4-4			Level 2, ±2KV	
	Surge	BS EN/EN61000-4-5			Level 2, ±1KV Line-Line	
	Conducted	BS EN/EN61000-4-6			Level 2, 10Vrms Criteria A	
	Voltage Dips and Interruptions	BS EN/EN61000-4-11			0%, 70% perf. Criteria B	
OTHERS						
MTBF (Typ.)	>10000Khrs MIL-HDBK-217F(25°C)					
DIMENSION (L*W*H)	A Type : 44.5*25*15mm (1.751*0.984*0.59 inch) ; B Type : 44.5*25.5*15mm (1.751*1.003*0.59 inch) C Type : 44.5*23*15.5mm (1.751*0.905*0.61 inch)					
PACKING	A, B Type : 11.2g ; 49pcs/per Tray, 637pcs/13 Tray/per carton C Type : 11.2g ; 56pcs/per Tray, 448pcs/8 Tray/per carton					
NOTE						
<p>1.All parameters NOT specially mentioned are measured at 230Vac input, rated load and 25°C of ambient temperature.</p> <p>2.Ripple & noise are measured at 20MHz of bandwidth by using a 12" twisted pair-wire terminated with a 0.1µF & 47µF parallel capacitor.</p> <p>3.Length of set up time is measured at first cold start. Turning ON/OFF the power supply may lead to increase of the set up time.</p> <p>4.When starting at a low temperature of -40°C, the output capacitor needs to be equipped with a solid capacitor to meet the load reduction curve requirements.</p> <p>5.The final equipment must be re-confirm that it still meet EMC directives. For guidance on how to perform these EMC tests, please refer to "EMI testing of component power supplies."(as available on http://www.meanwell.com)</p> <p>※ Product Liability Disclaimer : For detailed information, please refer to https://www.meanwell.com/serviceDisclaimer.aspx</p>						

Derating Curve

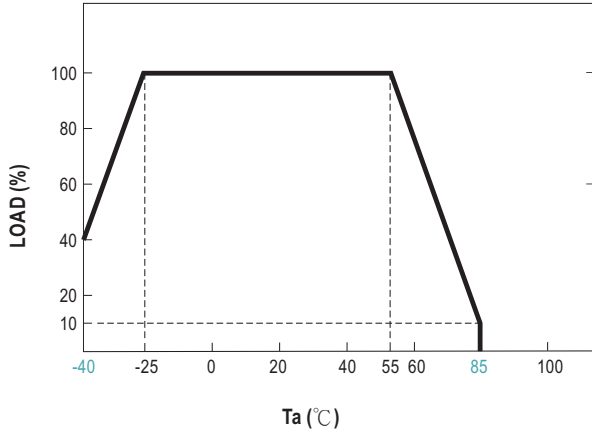

Output Derating VS Input Voltage

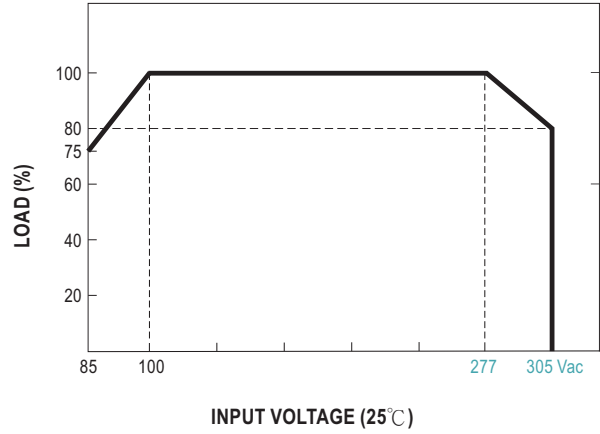

Additional Circuit Design Reference

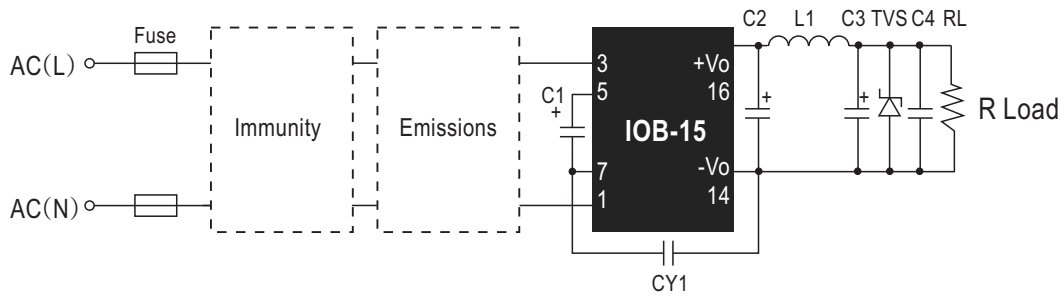

IOB-15 Series additional component selection guide (no EMC devices)								
Model No.	FUSE (required)	C1 (required)	C2 ² (required)	L1 (required)	C3 ² (required)	C4	CY1 (required)	TVS
IOB-15-3.3 <input type="checkbox"/>	1A/300V	33uF/450V	470uF/16V (Polymer capacitor)	2.2uH (Max, 22mΩ)	220uF/16V	0.1uF/50V	2.2nF/400Vac	SMBJ7.0A
IOB-15-05 <input type="checkbox"/>								SMBJ7.0A
IOB-15-09 <input type="checkbox"/>								SMBJ12A
IOB-15-12 <input type="checkbox"/>								SMBJ20A
IOB-15-15 <input type="checkbox"/>								SMBJ20A
IOB-15-24 <input type="checkbox"/>								SMBJ30A

- Note: 1. C2,C3 is recommended to be a high frequency electrolytic capacitor with low ESR.
 2. Recommended to use a polymer capacitor (at -40°C) with at least 20% margin on voltage rating.

■ Additional EMC Suggestion Circuit

IOB-15 Series Environmental and EMC selection guide					
Recommended circuit	Typical industry	Input voltage range	Environment temperature	Emissions	Immunity
1	General purpose	85~305Vac	-40°C to 85°C	Class A	Class III
2	Smart home, home appliances, intelligent building, intelligent agriculture		-25°C to 55°C	Class B	Class III
3	Indoor industrial		-25°C to 55°C	Class B	Class IV
4	Outdoor, video monitoring, charging point, communications, security		-40°C to 85°C	Class A	Class IV

Immunity design circuits reference		Emissions design circuits reference	
Class III	Class IV	Class A	Class B

1.Circuit 1 - Basic - Application

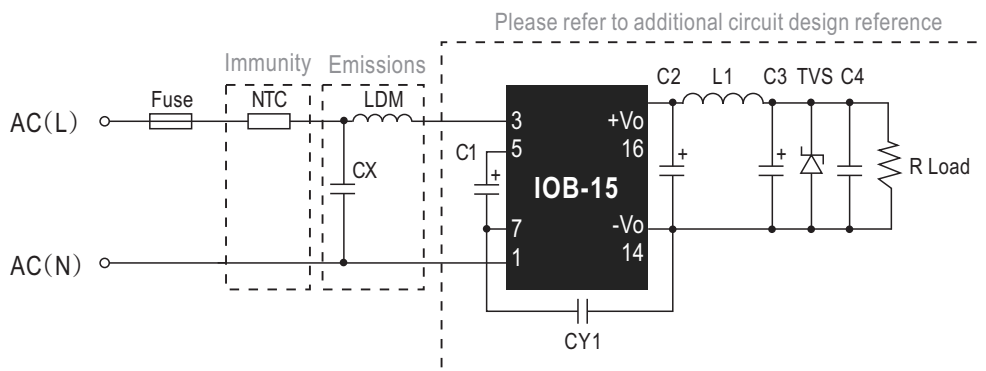

Ambient temperature range	Immunity Class	Emissions Class
-40° C ~85° C	Class III	Class A

Component	Recommended value
NTC	10D-10
LDM	1.2mH (min: 0.4A, max: 4Ω)
CX	0.1uF/310Vac
Fuse(required)	1A/300V,slow blow

2.Circuit 2 - Indoor Civil / Indoor General Environment

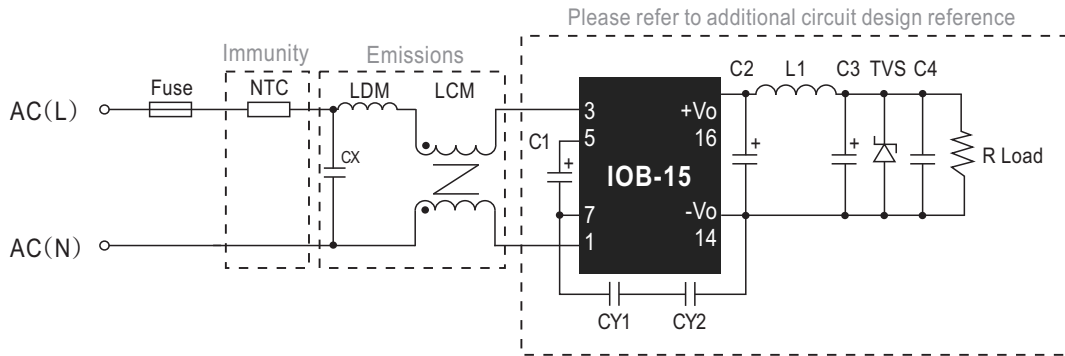

Ambient temperature range	Immunity Class	Emissions Class
-25°C ~ 55°C	Class III	Class B

Component	Recommended value
NTC	10D-10
CY1 (CY2)	2.2nF/400Vac
LCM	10mH (min: 0.4A,max:600mΩ)
LDM	0.33mH (min: 0.4A,max:1Ω)
CX	0.22uF/310Vac
Fuse (required)	1A/300V, slow blow

Note: When designing applications for household use (e.g. Smart Home or Home Appliance application), two Y-Caps (CY1 & CY2) valued at 2.2nF/400Vac each) are required in series to satisfy 60335 household safety requirements. Non-household applications can use one Y-Cap (CY1 valued at 2.2nF/400Vac)

3.Circuit 3 - Indoor General Environment

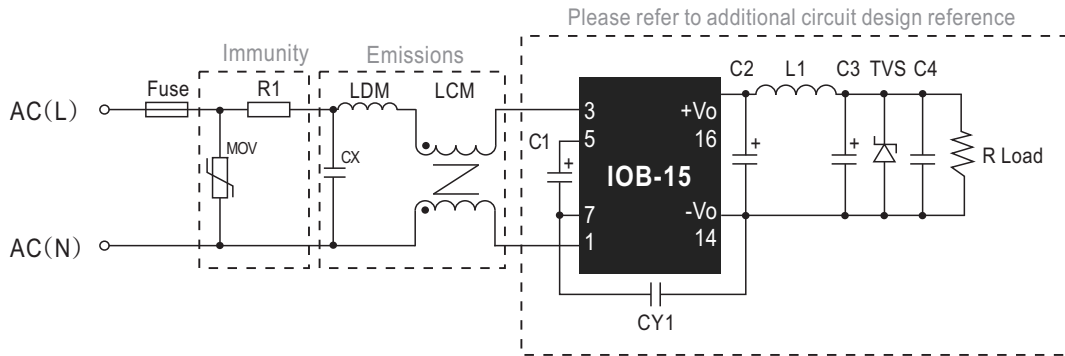

Ambient temperature range	Immunity Class	Emissions Class
-25°C ~ 55°C	Class IV	Class B

Component	Recommended value
MOV	S14K350
CY1	2.2nF/400Vac
CX	0.22uF/310Vac
LCM	10mH (min: 0.4A,max:600mΩ)
LDM	0.33mH (min: 0.4A,max:1Ω)
R1(wire-wound resistor, required)	12Ω/3W
Fuse (required)	2A/300V, slow blow

4.Circuit 4 - Outdoor General Environment

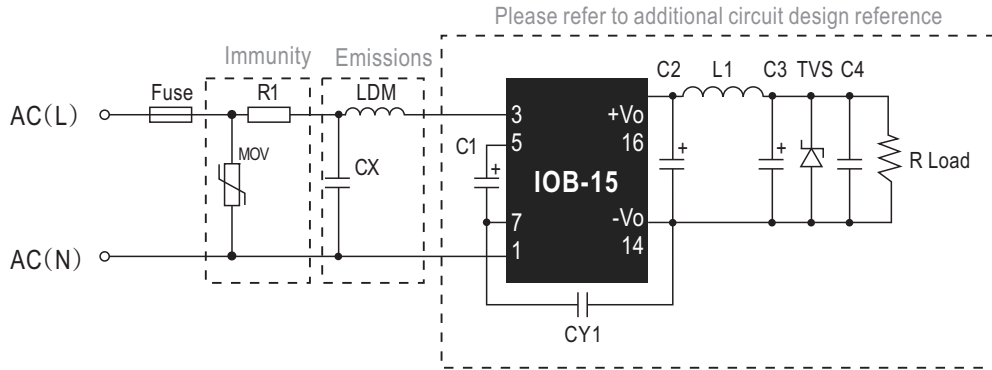

Ambient temperature range	Immunity Class	Emissions Class
-40° C ~ 85° C	Class IV	Class A

Component	Recommended value
MOV	D14K350
LDM	1.2mH (min: 0.4A, max: 4Ω)
CX	0.1uF/310Vac
R1 (wire-wound resistor, required)	12Ω/3W
FUSE (required)	2A/300V, slow-blow

Note: R1 must be a wire-wound resistor; do not use a chip or carbon film resistor.

Mechanical Specification

- All dimensions in mm
- Pin section tolerance: $\pm 0.3\text{mm}$
- General tolerance: $\pm 0.5\text{mm}$

IOB-15-xxA (Edge Connector Type)

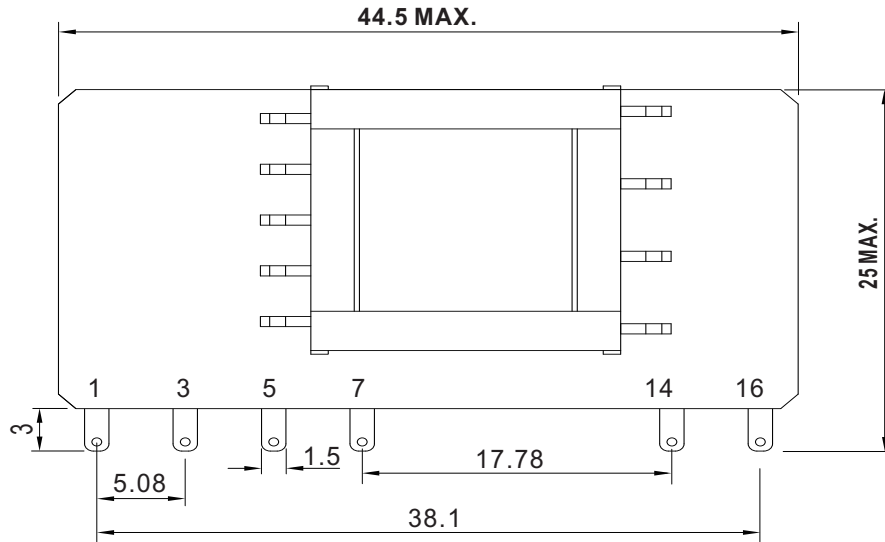

(Front View)

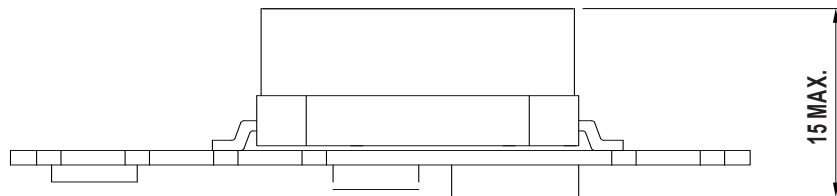

(Side View)

Pin Assignment

Pin-Out	
Pin No.	Output
1	AC/N
3	AC/L
5	+V(cap)
7	-V(cap)
14	-Vout
16	+Vout

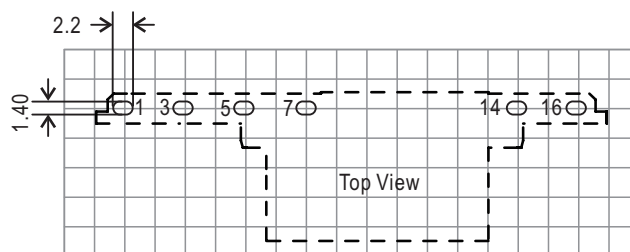

Note: Grid 2.54*2.54mm

IOB-15-xxB (Vertical Type)

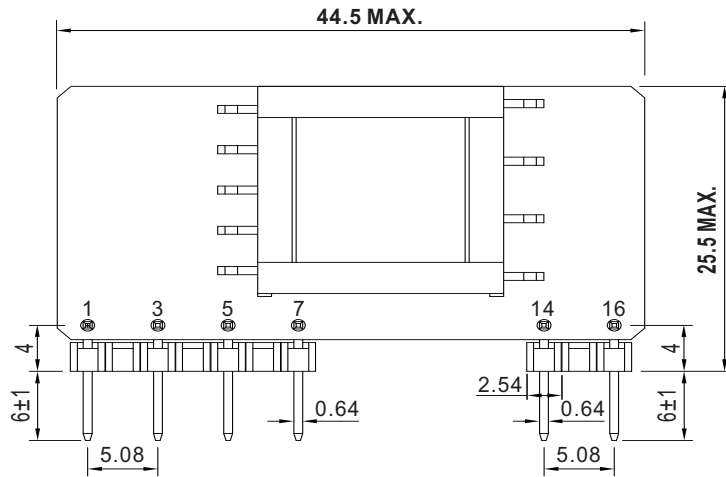

(Front View)

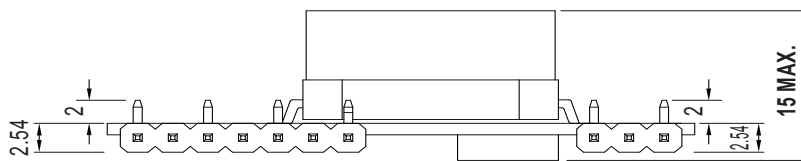

(Side View)

■ Pin Assignment

Pin-Out	
Pin No.	Output
1	AC/N
3	AC/L
5	+V(cap)
7	-V(cap)
14	-Vout
16	+Vout

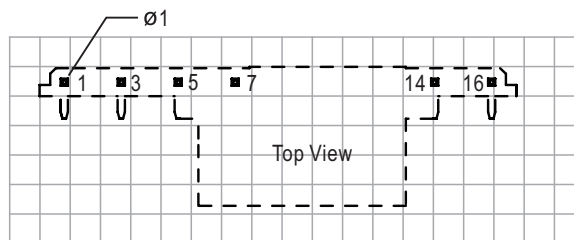

Note: Grid 2.54*2.54mm

IOB-15-xxC (Horizontal Type)

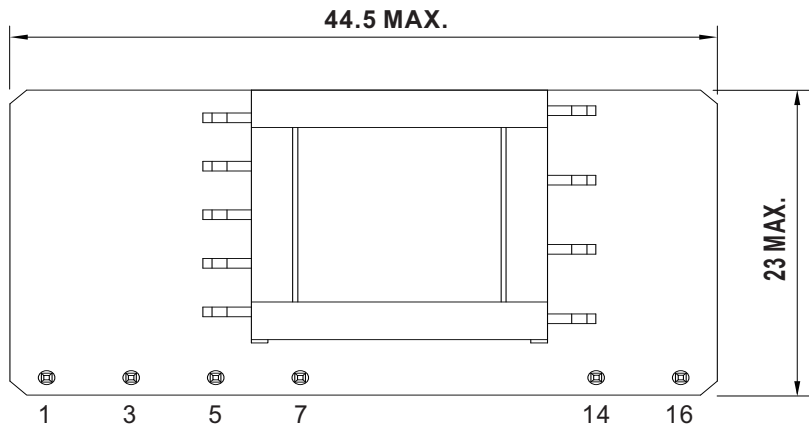

(Front View)

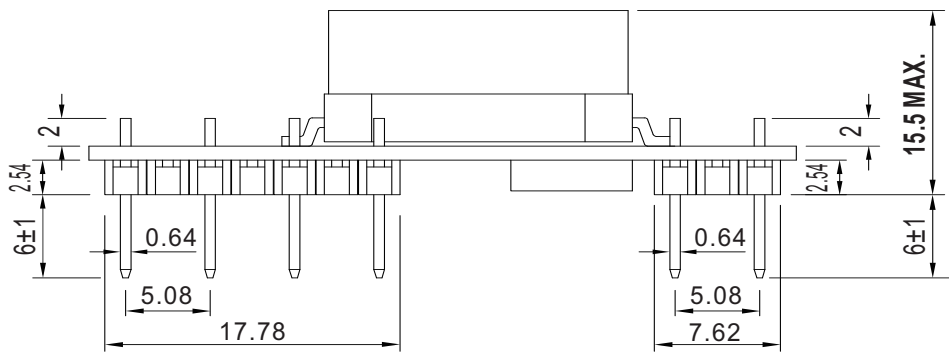

(Side View)

Pin Assignment

Pin-Out	
Pin No.	Output
1	AC/N
3	AC/L
5	+V(cap)
7	-V(cap)
14	-Vout
16	+Vout

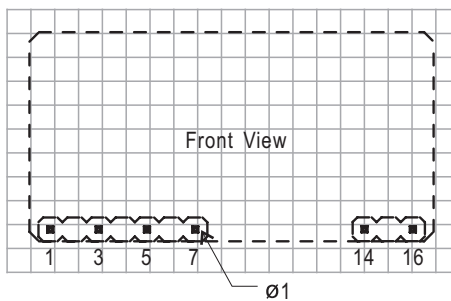

Note: Grid 2.54*2.54mm

■ Packing

Standard Packing	IOB-15-xxA /xxB			
	MPQ Per Tray(PCS)	One Tray G.W.	Max. Q'TY/ Carton(PCS)	One Carton G.W.
<p>Unit : mm</p> <p>IOB-15-xxA/xxB</p> <p>Antistatic Plastic blister</p> <p>CARTON L457 x W342 x H227</p>	49	660g	637	10.5Kg

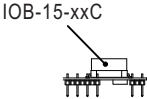
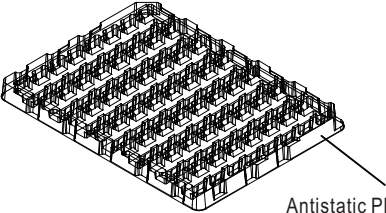
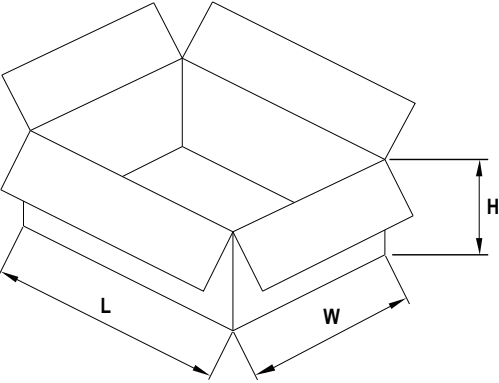
Standard Packing	IOB-15-xxC			
	MPQ Per Tray(PCS)	One Tray G.W.	Max. Q'TY/ Carton(PCS)	One Carton G.W.
<p>Unit : mm</p>  <p>IOB-15-xxC</p>  <p>Antistatic Plastic blister</p>  <p>CARTON L457 x W342 x H227</p>	56	745g	448	8.5Kg

Installation Manual

Please refer to : <http://www.meanwell.com/manual.html>